



**CSL and CSIL Series Hopper Loaders – Series One Control**  
Reference Manual (PN: 882.00237.00) for  
**Complete Operation and Installation Instructions**  
(Available online at [www.acscustomerservice.com](http://www.acscustomerservice.com))

---

### **Quickstart Installation Checklist**

(Refer to main manual for complete installation instructions)

1. Mount hopper mounting flange to machine bin or feed throat using rivets if possible.
2. Ensure that unit is level for proper operation.
3. Attach flex hose to unit and pickup wand. Secure with hose clamps.
4. Attach clean, dry 80-120 psi air.
5. Plug unit into grounded three-prong receptacle.

---

### **Unit Operation**

(Refer to main manual for complete operating instructions)

1. Insert pickup wand into desired material.
2. Move the power switch on the control panel to the **ON** position.

**Note:** *The hopper loader loads itself until full, then dumps and repeats.  
It pauses only when the machine bin below is full.*

3. To stop sequence, move the power switch to the **OFF** position.

### Parts Location

(See next page for Spare Parts List)

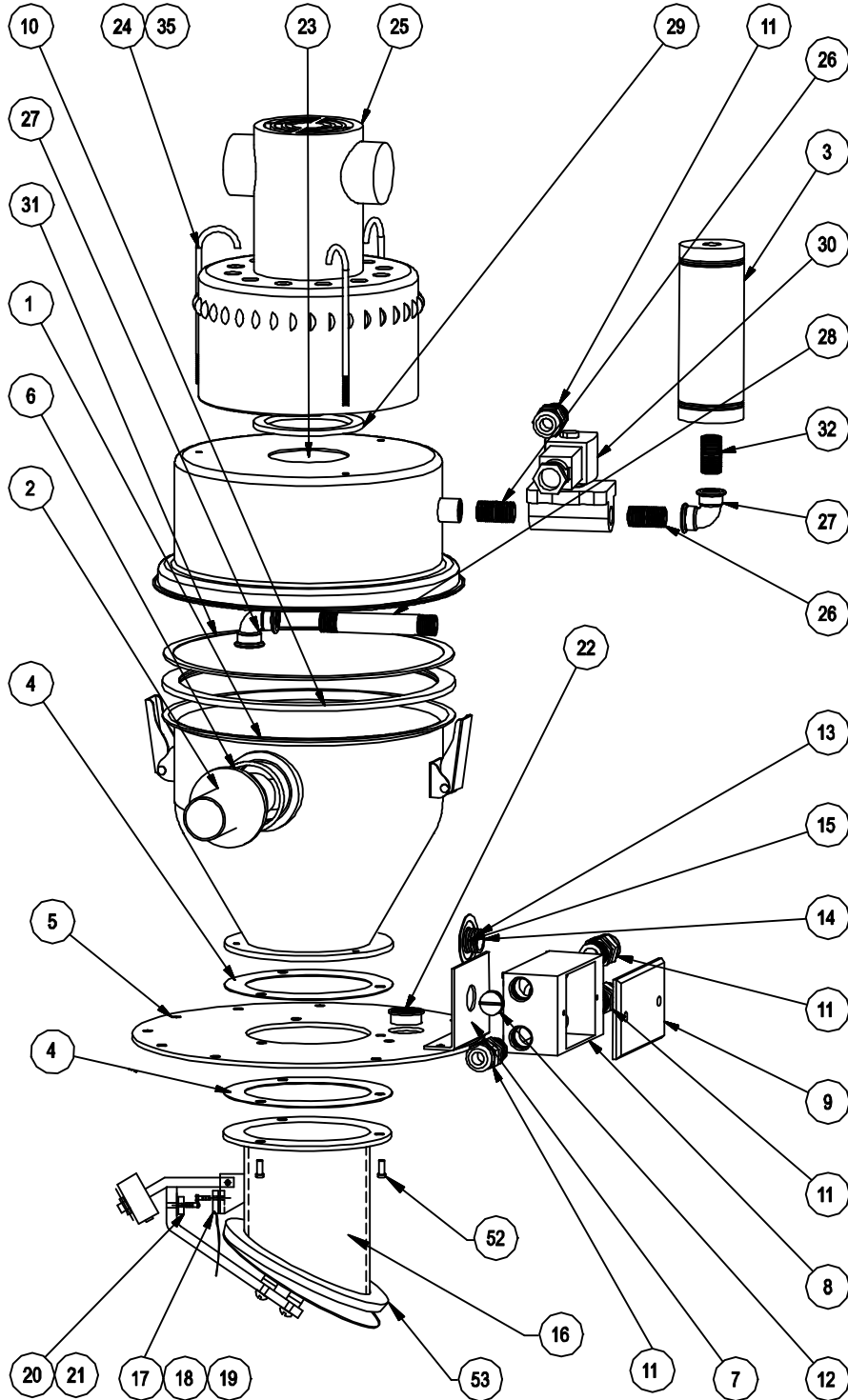



**CSL and CSIL Series Hopper Loaders – Series One Control**  
**Reference Manual (PN: 882.00237.00) for**  
**Complete Operation and Installation Instructions**  
 (Available online at [www.acscustomerservice.com](http://www.acscustomerservice.com))

**Spare Parts List**  
 (See previous page for Parts Location)

Part	Variation	CSL/CSIL 03	CSL/CSIL 06/11	CSL 23/45
Filter 1	Polyester Glazed (Standard)	A0565928	A0565929	A0565930
	Nylon (Optional)	A0565931	A0565932	A0565933
Motor 2	115V	A0542189	W00020081	
	Spare Brushes	W00020083		
	230V	A0542190	W00020082	
	Spare Brushes	W00020176		
Solenoid 3	115V	A0556547		
	230V	A0556808		
Throat Gasket 4	Standard Temp (Black)	N/A	Version 1 – N/A	
	High Temp (Orange)	N/A	Version 2 - W00012559	
			Version 1 – N/A	
FDA Grade (White)	N/A	Version 2 - W00018024		
Material Level Sensor 5	Switch	CSIL – N/A		Version 1 - A0563514
		CSL - A0556805		Version 2 - A0533925
	Magnet	N/A		Version 1 - A0563515
				Version 2 - A0533924
Pickup Wand Assembly	Wand	A0533933		
	Hose	W00017594		
	Hose Clamp	W00001917		

**Note:** Refer to the main manual for a complete Spare Parts List.



**CSL and CSIL Series Hopper Loaders – Series One Control**  
Reference Manual (PN: 882.00237.00) for  
**Complete Operation and Installation Instructions**  
(Available online at [www.acscustomerservice.com](http://www.acscustomerservice.com))

**Troubleshooting – Quick Guide**

<b>Problem</b>	<b>Possible Cause</b>	<b>Solution</b>
Unit does not work	No power to control box	Plug in power cord. Check main disconnect.
	Power switch is off	Turn ON control box.
	Fuse blown	Replace the MDL 10 fuse.
	Bin is full	Unit will resume operation when material level drops - this is NORMAL.
	Fouled flapper discharge valve	Remove obstruction - check for free movement of flapper assembly.
Hopper does not fill completely	Material supply is low	Refill material supply.
	Wand not properly positioned in material supply	Adjust material wand at material pickup point.
	Conveying sequence is too short	Select a more suitable sequence - see manual for more information.
	Pickup wand not adjusted for material flow characteristics	Adjust material probe to compensate for material - see manual for more information.
	Filter is dirty/clogged	Clean/replace filter as needed.
Hopper overfills	Loading sequence is too long	Select a more suitable sequence - see manual for more information.