

## Quickstart Installation Checklist

(Refer to main manual for complete installation instructions)

1. Mount hopper mounting flange to machine bin or feed throat, using rivets if possible.

**Note: Ensure that unit is level for proper operation.**

2. Attach flex hose to unit and pickup wand. Secure it with hose clamps.
  3. Attach clean, dry 80-120psi air.
  4. Plug unit into grounded three-prong receptacle.
- 

## Unit Operation

(Refer to main manual for complete operating instructions)

1. Insert pickup wand into desired material.

2. Press the  START/STOP **START/STOP** key.

**Note: The hopper loader loads itself until full, then dumps and repeats. It pauses only when the machine bin below is full.**

3. To stop the unit from loading, press the  START/STOP **START/STOP** key.

### For Proportioning Models

1. Insert pickup wands into desired materials.

2. Press  SCROLL **SCROLL** key repeatedly until screen displays “3”.

3. Press the  START/STOP **START/STOP/SELECT** key to select the “% of MAT'L B” menu.

4. Use the  **UP** and  **DOWN** keys to set the desired % of Material B.

5. Press the  START/STOP **START/STOP/SELECT** key to set this value.

6. Press the  START/STOP **START/STOP/SELECT** key again to start the hopper loader.

**Spare Parts Location**  
 (See next page for Spare Parts List)

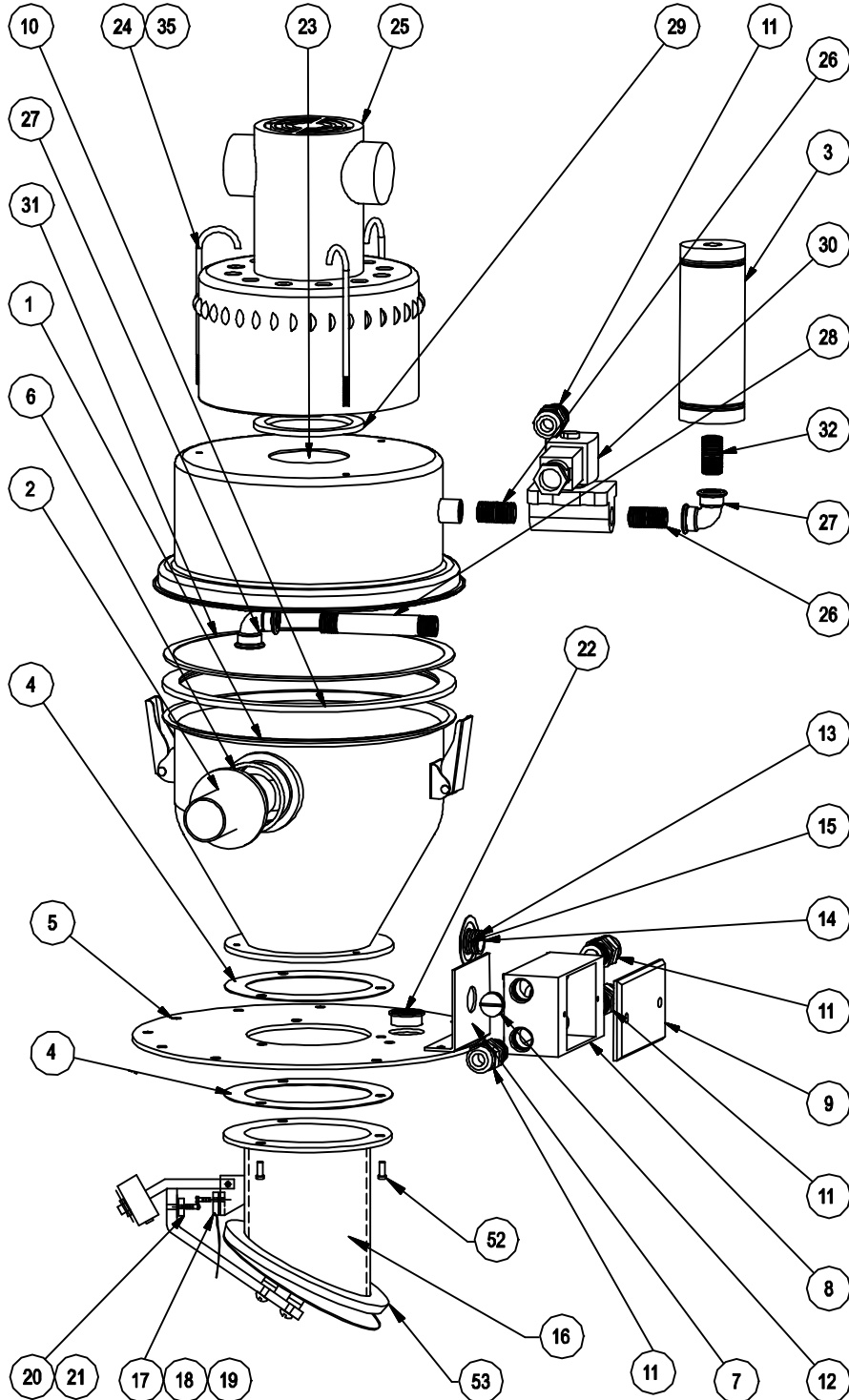



**CSL and CSIL Series Hopper Loaders – Series One Plus Control**  
**Reference Manual (PN: 882.00237.00) for**  
**Complete Operation and Installation Instructions**  
 (Available online at [www.acscustomerservice.com](http://www.acscustomerservice.com))

**Spare Parts List**

(See previous page for Spare Parts Location)

Part	Variation	CSL/CSIL 03	CSL/CSIL 06/11	CSL 23/45
<b>Filter</b> 1	Polyester Glazed (Standard)	A0565928	A0565929	A0565930
	Nylon (Optional)	A0565931	A0565932	A0565933
<b>Motor</b> 2	115V	A0542189	W00020081	
	Spare Brushes	W00020083		
	230V	A0542190	W00020082	
	Spare Brushes	W00020176		
<b>Solenoid</b> 3	115V	A0556547		
	230V	A0556808		
<b>Throat Gasket</b> 4	Standard Temp (Black)	N/A	Version 1 – N/A Version 2 - W00012559	
	High Temp (Orange)	N/A	Version 1 – N/A Version 2 - W00018024	
	FDA Grade (White)	N/A	Version 1 – N/A Version 2 - W00016136	
<b>Material Level Sensor</b> 5	Switch	CSIL – N/A CSL - A0556805	Version 1 - A0563514 Version 2 - A0533925	
	Magnet	N/A	Version 1 - A0563515 Version 2 - A0533924	
<b>Pickup Wand Assembly</b>	Wand	A0533933		
	Hose	W00017594		
	Hose Clamp	W00001917		

**NOTE: Refer to the main manual for a complete Spare Parts List.**



**CSL and CSIL Series Hopper Loaders – Series One Plus Control**  
**Reference Manual (PN: 882.00237.00) for**  
**Complete Operation and Installation Instructions**  
 (Available online at [www.acscustomerservice.com](http://www.acscustomerservice.com))

**Troubleshooting – Quick Guide**

<b>Problem</b>	<b>Possible Cause</b>	<b>Solution</b>
No LED display	No power to control box	Plug in power cord. Check main disconnect.
	Power switch is off	Turn ON control box.
	External fuse 1FU is blown	Replace fuse 1FU.
	Internal fuse FU2 is blown	Replace fuse FU2.
	TB1 is disconnected/loose	Reconnect or tighten TB1.
	Loose wiring in control	Check/tighten controller wiring.
Colortronic is displayed at power-up, but vacuum motor doesn't start when the <b>START/STOP</b> key is pressed.	Bin full sensor switch is tripped	Wait for machine bin material level to drop, then restart the hopper loader.
	Misaligned bin full sensor switch magnet	Realign magnet.
	Bin full sensor switch wiring is loose/disconnected	Repair the wiring fault.
	Pickup wand not adjusted for material flow characteristics	Adjust material probe to compensate for material - see manual for more information.
	Filter is dirty/clogged	Clean/replace filter as needed.
Control appears to work, but vacuum never starts.	Vacuum motor unplugged	Plug in vacuum motor.
	Vacuum time set to zero (0) on Menu 1	Reset Menu 1 to an appropriate time.
	Solid-state relay has failed	Replace solid-state relay.
Hopper does not fill completely	Wand not properly positioned in material supply	Adjust material wand at material pickup point.
	Vacuum time is set too low	Set Menu 1 to an appropriate value.
	Pickup wand not adjusted for material flow characteristics	Adjust material probe to compensate for material - see manual for more info.
	Filter is dirty/clogged	Clean/replace filter as needed.
Proximity switch trips before tank is full	Material residue buildup on proximity sensor	Clean proximity sensor.
	Proximity sensor sensitivity is set too high	Reduce sensitivity of sensor.
	Control wiring connections on circuit board are loose.	Secure connections on circuit board.
Proportioning valve doesn't shift (PP models only)	No compressed air	Connect to 80psi air supply.
	Defective valve or solenoid	Repair or replace as needed.
	TB1 is disconnected/loose	Tighten TB1 connections.