

Quick Start Installation Checklist

(Refer to the owner's manual for complete installation instructions).

Machine Mount Installation (See manual for floor and wall mount configurations)

1. Check the CPV single outlet tube diameter and the hopper loader inlet size to be sure you have the necessary coupler and transition tube (if needed) to connect the CPV to the hopper inlet.
2. Bevel and smooth the hopper loader or vacuum hopper inlet tube to prevent damage to the O-rings inside the tube coupler.
3. Apply silicone lubricant or equivalent to the inside of the tube coupler to ease insertion.
4. Insert the single material outlet tube into the tube coupler past the O-ring.
5. Slide the CPV onto the hopper loader or vacuum hopper. **(Be sure the tube passes the O-ring for an air-tight seal).**
6. Tighten the set screws in the tube coupler to lock the CPV in place.
7. Attach the material pick-up wands to the CPV inlet tubes using flex hose and hose clamps.

Installing the CPV-A Autoload Knob Box Control

(The CPV-A control package is designed exclusively for use with the hopper loader).

1. Disconnect and lock out power to the Hopper.
2. Wire the CPV Material A and B solenoids to Hopper Loader control box using 16AWG wire.
3. Remove Jumper W3 installed between Terminals 13 and 14 on Terminal Block TB1 in the Hopper Loader control box.
4. Toggle the power switch on the Hopper Loader to the ON position. This switch must be ON to use the Knob Box Control as a remote ON/OFF.
5. Plug the white logic plug connected to the CPV knob box into the receptacle marked J2 on the left side of the control enclosure.

(Figure 1: CPV-A to Loader Wiring Diagram)

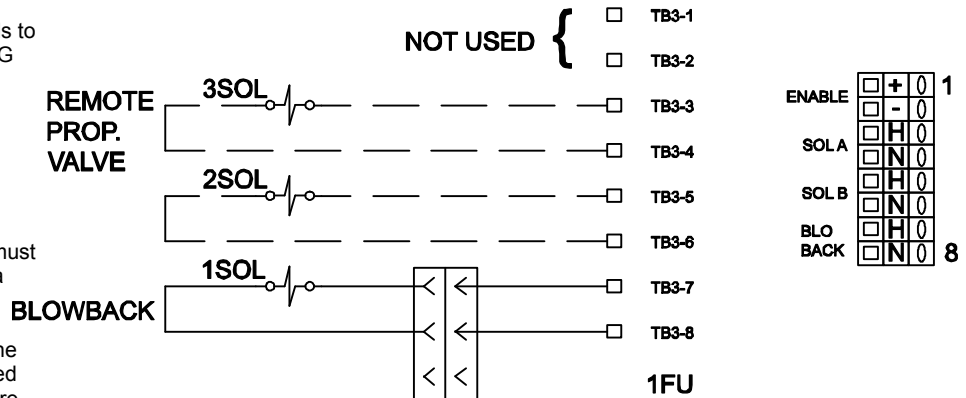

Installing the CPV-B and CPV-D Standalone for Central Vacuum Systems

(The B and D CPV's are for use with central vacuum systems. They will convert an existing vacuum hopper into a proportioning unit).

1. Remove the cover from the control enclosure. Turn it over to access to the eight-pin socket at the base of the timer.
2. Use #14AWG leads to wire terminals three and six to Solenoid 1, material A, in the CPV. Splice leads together in the CPV shroud.
3. Use #14AWG leads to wire terminals four and five to Solenoid 2, material B, in the CPV. Splice leads together in the CPV shroud.
4. Use #14AWG leads to wire terminals one and eight to the existing sequence tee valve.
5. Replace the cover of the enclosure and tighten the screws.

(Figure 2: CPV-B or CPV-D Standalone Connection Diagram)

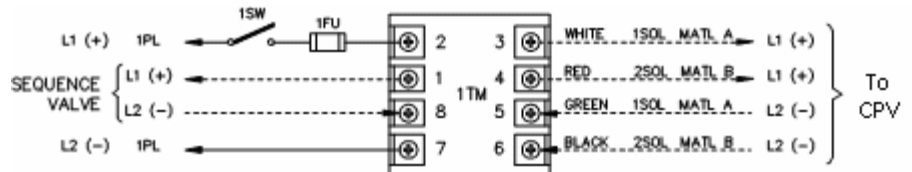

Spare Parts Location
 (See next page for Spare Parts List)

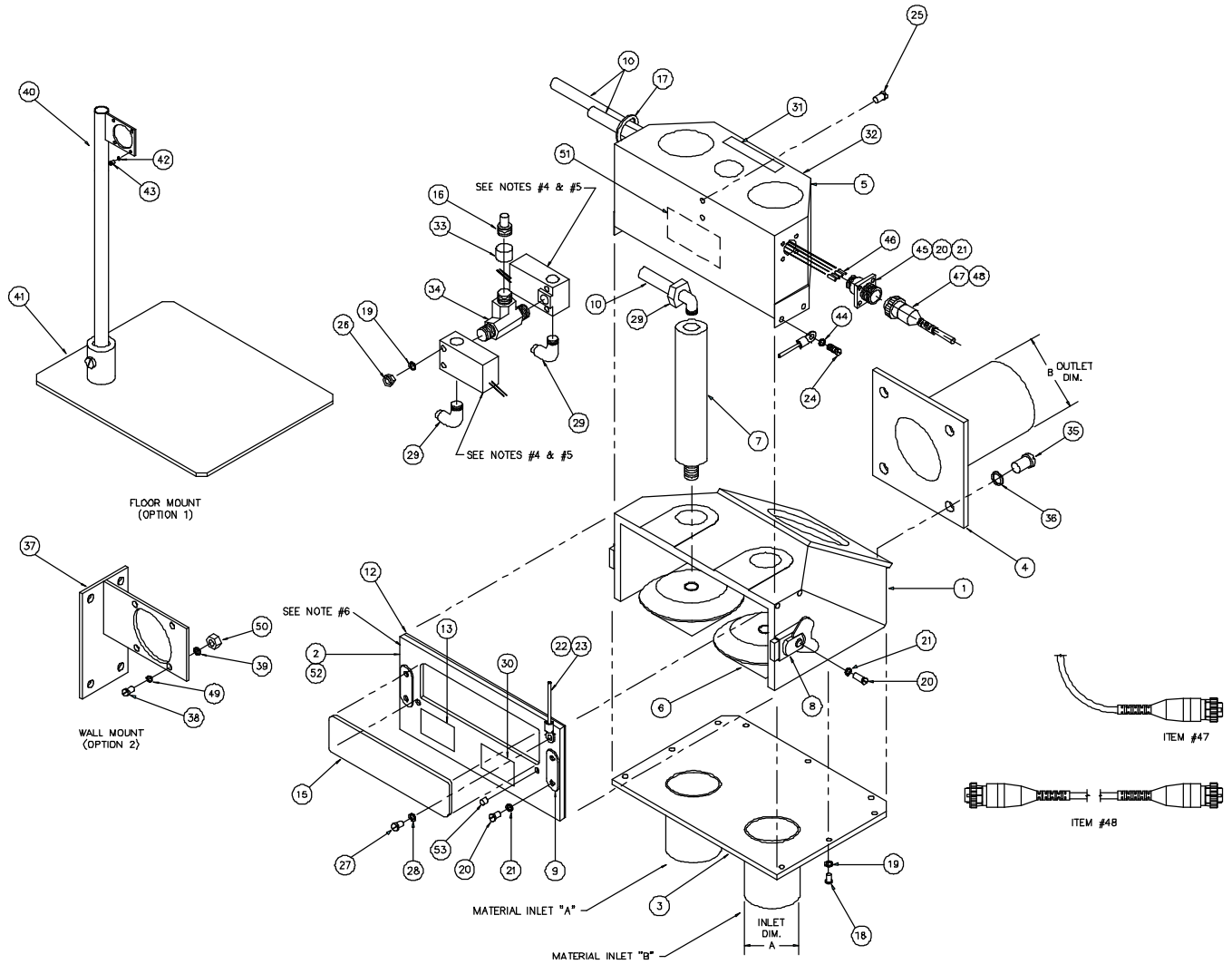



CPV Remote Proportioning Valve
Reference Manual (PN: 882.00270.00) for
Complete Operation and Installation Instructions
 (Available online at www.acscustomerservice.com)

Spare Parts List
 (See previous page for Spare Parts Location)

Item	QTY	Part #	Description/Print #
1	1	W00533550	Valve Body
2	1	W00533551	Cover
3	1	Refer to Figure #1 in the owner's manual	Inlet Plate
4	1	Refer to Figure #2 in the owner's manual	Outlet Tube
5	1	W00533562	Shroud
6	2	W00533565	Plunger
7	2	W00533566	Air Cylinder
8	2	W00533567	Latch, Simmons Camlock
9	2	W00533568	Catch, for Camlock Latch
10	2FT	A0069307	1/4" Poly Tubing
11	2	Refer to Figure #3 in the owner's manual	Solenoid, 3-Way
12	1	A0548225	Gasket, Hi-Temp, CPV
13	1	W00533573	Label Warning
14	1	W00533575	O&I Manual
15	1	W00533576	Sight Glass
16	1	A0535017	Nipple, for Air Connection 1/8 in MNPT
17	1	W00533595	Grommet, Rubber
18	9	W00008528	Screw, 6-32 x 7/16 RHM
19	11	A0104531	Washer, #6 Lock
20	12	W00000907	Screw, 4-40 x 3/16 RHM
21	12	A0535082	Washer, #4 Lock CAD.PLTD.
22	2	A0103129	Terminal Ring/(W00533569)
23	1FT	W0013647	Cable, 1/16 Dia.,ss/(W00533569)
24	4	A0102356	Screw, 8-32x3/8, RHM
25	2	W00000913	Screw, 6-32x7/8
26	2	W00000958	Nut, 6-32, HEX
27	1	W00000921	Screw, 10-32 x 1/4, RD. HD. MACH
28	1	W00000947	Washer, #10 Lock
29	4	W00001142	Fit, 1/4 Poly , 90 Deg. Brass
30	1	W00009798	Label, "Do not exceed 80 PSIG"
31	1	Refer to Figure #4 in the owner's manual	Label, Voltage
32	1	A0534770	Label, Logo
33	1	A0015486	Coupler
34	1	A0535016	Fit, 1/8, BR, MNPT, MNPT, MNPT
35	4	W00013527	BLT, 1/4-20, x 5/8, HEX, PLTD
36	4	W00000945	Washer, 1/4 IN., Lock
37	1	W0053564	Bracket, Wall Mount
38	4	W00052330	Screw, 1/4-20 x 1.00 IN., HEX, SS
39	4	W00000945	Washer, 1/4, Lock, PLTD
40	1	W00533561	Standard Floor Mount
41	1	W00012260	Base Plate/ (5008)
42	4	W00000945	Washer, 1/4, Lock, PLTD
43	4	W00052330	Screw, 1/4-20 x 1.00 IN., HEX, SS
44	4	A0104523	Washer, Lock #8
45	1	A0536451	Receptacle
46	4	A0536454	Pin
47	1	A0539478	ASSY, Cable, 26' CPV – P
48	1	A0539119	ASSY Cable 26' CPV – P
49	1	W00002373	Washer, Flat, WI, 3/16"
50	1	W00000360	Nut, HEX, PLTD, 1/4-20
51	1	A0534770	LBL, SML, Logo
52	1	A0565901	Plate, CPV Valve
53	2	W00012471	RVT, POP, 3/16, USM#AD.66H, Dome



CPV Remote Proportioning Valve
Reference Manual (PN: 882.00270.00) for
Complete Operation and Installation Instructions
 (Available online at www.acscustomerservice.com)

Troubleshooting – Quick Guide

Problem	Possible cause	Solution
Control is on and working, but valve does not work.	Faulty compressed air connection to valve.	Repair connection/replace connector. Must have minimum 60 psi.
	Inadequate incoming vacuum signal and voltage.	Locate problem, repair/replace as needed.
	Loose connection wiring in control box.	Repair/replace as needed.
	Improper shroud solenoid voltage compared to control output voltage.	Compare voltage rating of solenoids in shroud to output voltage of controls.
Control does not work.	Inadequate voltage.	Check supply voltage.
		Make sure the unit has power.
	Loose control wiring in control box.	Repair as needed.
Sudden loss in conveying rate. Possible loss of up to 20% conveying rate compared to non-proportioning unit.	Control malfunction.	Repair as needed.
	Valve jammed with material.	Clean out valve.
	Inadequate air pressure.	Correct as needed. Minimum 60 psi required for operation.
	Worn plungers.	Replace plungers (Part No. W00533565).
	Clogged filter hopper.	Clean or replace filter.
	Excessive vacuum leaks/loose connections to valve.	Repair/replace as needed.
	Worn cover seal.	Repair/replace as needed.
Plungers move slowly, stick, or do not seal properly.	Inadequate air pressure.	Correct as needed. Minimum 60 psi required for operation.
	Inadequate lubrication of air cylinder.	Lubricate air cylinder.
	Solenoids are malfunctioning.	Repair/replace as needed.
	Worn/malfunctioning plungers.	Repair/replace plungers as needed.
	Sticking plungers.	Replace air cylinder.
Consult factory.		