

Typical application of one C-Flex M feeder as part of a multi-feeder line.

- A C-Flex M Feeder
- B Load Cell (optional)
- C Controller (gravimetric or volumetric)

Component A is described below.

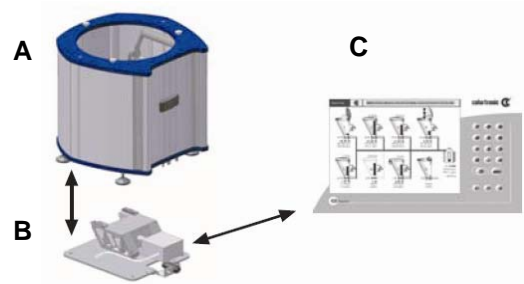

C-Flex M is designed to offer the greatest flexibility in flexible walled feeder design and construction.

C-Flex M is ideally suited for dosing powders, pellets, granulates, regrinds, fibers, and flakes in both continuous and batching processes. Colortronic's unique removable flexible hopper provides two huge advantages over traditional feeder designs. Firstly, the quick exchange hopper enables the user to clean and change materials in less than one minute.

Secondly, screw hoppers are interchangeable, allowing the user to configure the feeder for nearly any type of material in a matter of minutes. In addition to high flexibility, high performance is assured since consistent screw fill is maintained and bridging eliminated through the use of a flexible polyurethane hopper that is activated by friction-free massaging rolls. The C-Flex M can be integrated into both gravimetric and volumetric systems.

C-Flex M is available in single and twin-screw models, and its modular design enables the user to upgrade the system easily and cost effectively.



Features

- Quick exchange hoppers remove from rear without the use of tools
- 2 exchangeable hoppers available
 - o Single Screw 15-51
 - o Twin Screw 20-22 mm
- The rotating massage rolls do not cause any abrasion to the polyurethane hopper
- Multiple settings of the massage rolls allow best optimization of the feeding process in the field
- DC planetary gear motor 106 W 23:1
- Modular design with high flexibility
- The design concept allows a very compact arrangement of several feeders for a multiple feeder configuration
- Combined screw paddle drive ratio 3.5:1
- Extension hoppers can be mounted directly on the flexible hopper

Options

- Gravimetric and volumetric controls
- Digital vibrating wire platform scale with 1:1,000,000 resolution, 150 kg capacity
- DC planetary gear motor 250 W 9:1
- AC planetary gear motor 240 W 14:1
- Extension hopper 50 liters
- Lids for automatic and manual refill
- Finger guards
- Mounting feet or wheels for easy installation or maneuvering
- Extended screws and tubes 400/450 mm
- Vertical material discharge
- Dust tight filters
- Refill stand to support refill valves and hoppers

Technical Information

Features

- Motor size: 0.1 kW
- Voltage: 220 V DC
- Maximum speed: 3200 min⁻¹
- Motor Class IP 54
- Speed reducers: 23:1 (0.1 kW)

Massage roll motor

- Gear Drive
- Speed reducers: i=3.5:1

Flexible Hopper

- Hopper volume: 10 Liter
- Weight:
 - volumetric 30 kg
 - gravimetric 35 kg

Extension module

- Hopper volume: 50 Liter

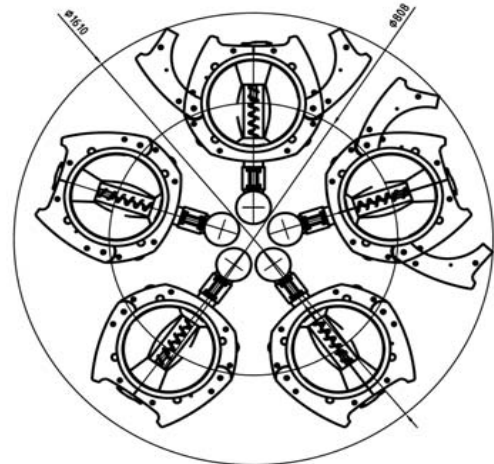
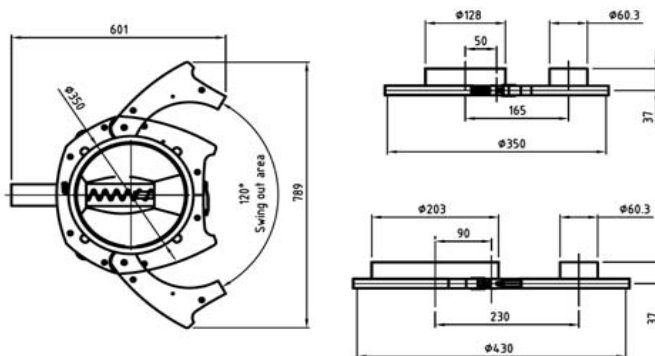
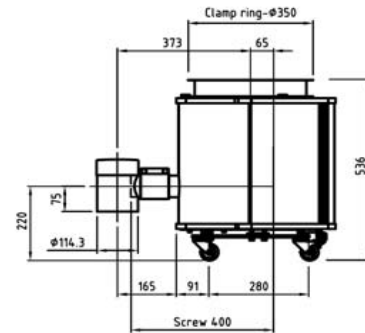
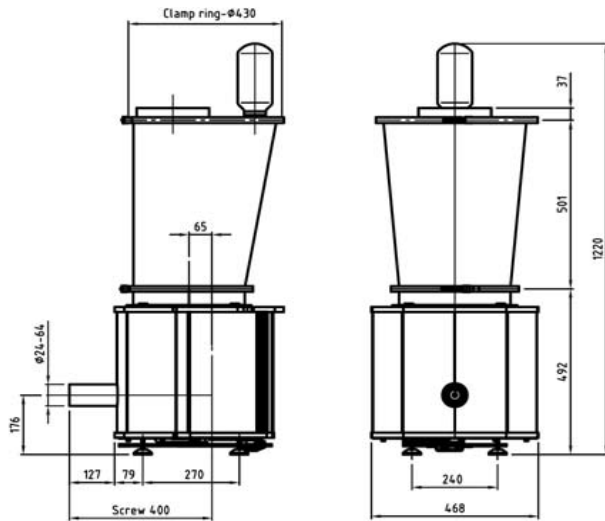

www.colortronicna.com

Corporate Headquarters:

Colortronic North America, Inc.
 4100 Market Place
 Flint, MI 48507
 Tel. 810-720-7300
 Fax. 810-720-2598
colortronicweb@corpemail.com

Colortronic Systems AG
 Hunzenschwil, Switzerland
 Tel: +41 62 689 25 25
 Fax: +41 62 689 25 26
info@colortronic.ch

Colortronic Systems GmbH
 Friedrichsdorf, Germany
 Tel: +49 61 75 7 92 167
 Fax: +49 61 75 7 92 284
ctsystems@colortronic.de