

Typical application of a dehumidifying drying system.

- A Dryer
- B Drying Hopper

Component B is described below.

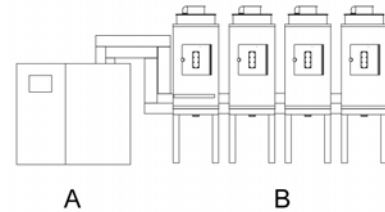

Brief Description

CD Series small drying hoppers are available in machine-mount and floor-mount configurations. They feature unique mass-flow design, full hopper insulation, and slide gate shut-off. Large door allows for easy cleanout.

Application

Drying of thermoplastic pellets and regrind, as part of a drying system. Colortronic drying hoppers are designed for continuous 24-hour operation.

Rugged, modular construction

The CD Series small drying hoppers are available in machine-mount and floor-mount configurations. They feature unique mass-flow design, full hopper insulation, and slide gate shut-off. The large access door allows for easy cleanout. These drying hoppers are designed to promote even heat distribution and material mass flow to ensure adequate drying throughout the hopper.



Standard Features

- Unique mass flow design
- Stainless steel construction (inside and out)
- Hinged access door (3.0 cu. ft. [85 liter] and larger models). Hinged access door on 1.7 cu. ft. (50 liter) model is optional.
- Dual-wall insulated cylinder and cone section
- Material drain spout
- Slide gate on machine mount and floor mount hoppers
- Extended length sight glass on the hopper door
- Drain port (standard on machine mount units) ①

① Not available on 0.4 cu. ft. model

Options

- Premium slide gate ①
- Drawer magnet with slide gate
- Thermometer
- Floor stand (less casters)
- Handle kit with casters for floor stand
- Flange transition from 7" to 4" SS ①
- Manual fill cover
- Level sensors ①
- Tubing transition
- Hopper dryer cart

Specifications

Model	CDx.x							
	0.4 ①	0.85 ①	1.7	1.7 w/ door	3.0	4.0	6.0	9.0
Capacity in cu. ft./lbs. (liters)	0.4 (11)	0.85 (25)	1.7 (50)		3.0 (85)	4.0 (110)	6.0 (170)	9.0 (250)
Air inlet/outlet OD, in inches (cm)	1.5" (3.8)		2.5" (6.4)					

① CD 0.4 and CD 0.85 models do not include access doors on the cylindrical section.

Dimensions, in. (cm)

Drying Hopper	A	B	C	D	E	F	H	J
CD-0.4	18 (46)	11 (28)	1.5 (3.8)	25 (64)	n/a ②	9 (22.9)	4 x 5.5 (10 x 14)	2 (5.0)
CD-0.85	25 (64)	14 (36)	2.5 (6.4)	25 (64)	31 (79)	12 (30.5)	7 x 7 (18 x 18)	2 (5.0)
CD-1.7	34 (86)	14 (36)	2.5 (6.4)	25 (64)	40 (102)	20 (50.8)	7 x 7 (18 x 18)	2 (5.0)
CD-3.0	38 (97)	22 (56)	2.5 (6.4)	25 (64)	44 (112)	20 (50.8)	7 x 7 (18 x 18)	3 (7.6)
CD-4.0	44 (112)	22 (56)	2.5 (6.4)	25 (64)	50 (127)	20 (50.8)	7 x 7 (18 x 18)	3 (7.6)
CD-6.0	56 (142)	22 (56)	2.5 (6.4)	25 (64)	62 (158)	20 (50.8)	7 x 7 (18 x 18)	3 (7.6)
CD-9.0	68 (173)	22 (56)	2.5 (6.4)	25 (64)	74 (188)	20 (50.8)	7 x 7 (18 x 18)	3 (7.6)

② Machine-mount adapter not available on CD 0.4 model.

③ Premium slide gate not available on CD 0.4 models

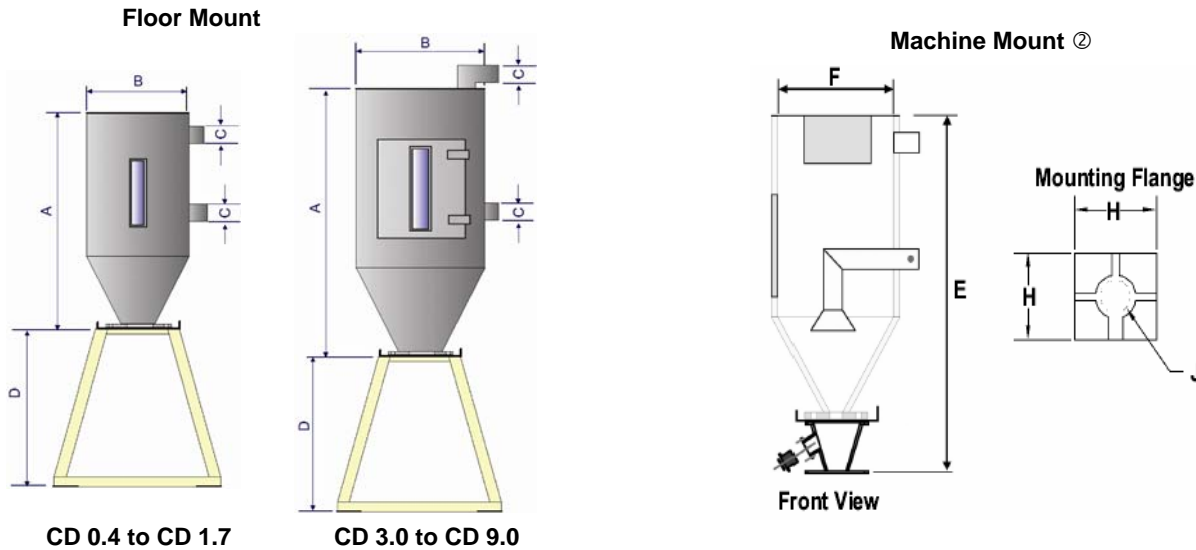

Portable Carts

Portable carts are available to mount one drying hopper to an CDA or CMD cabinet-style dryer.

4" diameter heavy-duty casters are standard on portable carts. Specify square slide gate with or without 10" TOC adapter.

Additional Features

- Smooth surface
- No material hang-ups
- Easy to clean
- Large access door with sight glass



www.colortronicna.com

Corporate Headquarters:

Colortronic North America, Inc.
4100 Market Place
Flint, MI 48507
Tel. 810-720-7300
Fax. 810-720-2598
colortronicweb@corpemail.com