

Brief Description

Application

MDT modular takeoff boxes from Colortronic are designed for hard to flow materials and provide durable construction in a simple, modular design. The MDT Series takeoff boxes feature stainless steel construction with stainless steel tube assemblies. The versatile modular design is compatible with a wide range of applications and allows for easy assembly and cleanout.

All compartments have adjustable tubes for air/material balancing.

Check the available clearance below flange, and make sure to pick the correct box type. Do not mix tube sizes without consulting the factory first.

Use MDT dual tube modular take-off boxes if you are conveying hard-to-flow materials, such as flakes or powders or if you are conveying any material over 200 equivalent feet. Consult factory for dry-air conveying applications or powder conveying applications. Maximum three (3) box stack up allowed (consult factory).

Standard Features

- Stainless steel box
- Stainless steel tubes
- Available sizes: 16" (406 mm) A style, 10" (254 mm) B style – square flanges.

Options

- Material clean-out gate
- Blank plate on bottom
- Adapter plate to mate to 7" x 7" or 9" x 9 square flange drying hoppers
- Take-off tubes: 1.5", 2", 2.5", 3", 3.5", 4"

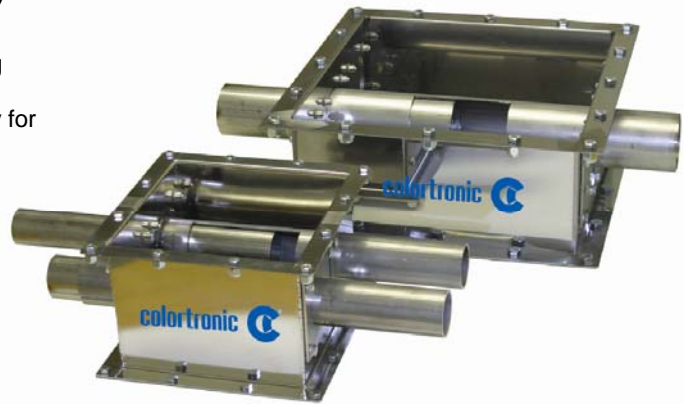

MDT Modular Take-Off Boxes

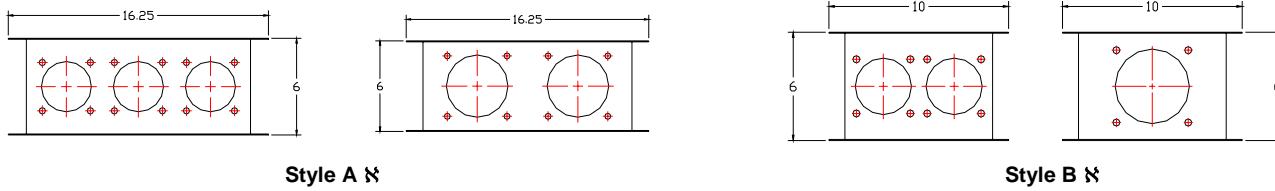

Specifications

Style	Square Flange Size, in. (mm)	Height, in. (mm)	Bolt pattern		Number of tubes per MDT box					
			Top	Bottom	1.5"	2.0"	2.5"	3.0"	3.5"	4.0"
A	16 (406)	6 (152)	16 holes	16 holes	3	3	3	3	3	2
B	16, 10 (406, 254)	8 (203)	16 holes	12 holes	3	3	3	1	1	1

☞ See chart for maximum number of tubes available per section

Bolt Patterns

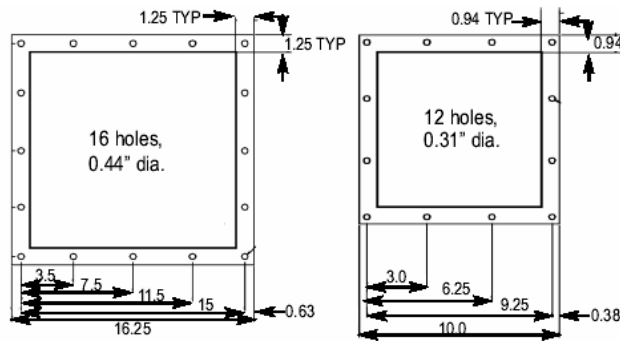

Clean-out Gates

Style	H, in. (cm)	W, in. (cm)	D, in. (cm)	A, in. (cm)	B, in. (cm)
A	6.94 (17.6)	16.25 (41.3)	16.25 (41.3)	3.14 (7.9)	6.38 (16.2)
B	4.31 (10.9)	10 (25.4)	10 (25.4)	3.06 (7.8)	6.38 (16.2)

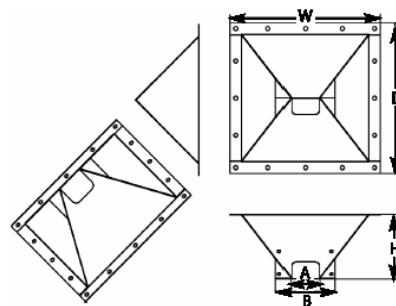

www.colortronicna.com

Corporate Headquarters:

Colortronic North America
4100 Market Place
Flint, MI 48507
PH: 810-720-7300
FX: 810-720-2598
colortronicweb@corpemail.com