

### MT Series Thermoforming Granulators

The Colortronic MT Series offers reclamation of thermoformed, extruded scrap, sheet, web and edge trim. With a standard 50 HP motor and throughput capacities up to 3,000 lbs/hr, there is a Colortronic granulator idea for your specific needs. The MT Series models include 14 x 56 and 14 x 62. Both provide heavy-duty construction and quiet operation. Double sealed bearings are lubricated for life.

#### Standard Features

- Open (wing) type design rotor
- Quick access to cutting chamber with swing down screen cradle for ease of service and cleaning
- Double sealed, outboard mounted heavy duty spherical bearings prevent bearing contamination
- 3 Chevron-positioned rotor knives scissor cut against the bed knives to provide optimum cutting efficiency with low power consumption
- Heavy duty construction allows noise reduction of 85 dBA or less for most applications
- Reinforced, heavy duty screen cradle
- Optimum cutting efficiency with Twinshear™ knife configuration

#### Optional Features

*Motor:*

- 40-100 HP REFC motors
- Special voltage (e.g. 208, 380, 415, 575)
- Magnetic disc break

*Infeed:*

- Dual feed hopper, pneumatic lift assembly, feed rolls, paddle rolls

*Discharge:*

- 8" or 10" airveyor chute

*Knives:*

- HCHC with TCSC

*Base:*

- Drum/Gaylord, angular, leg type

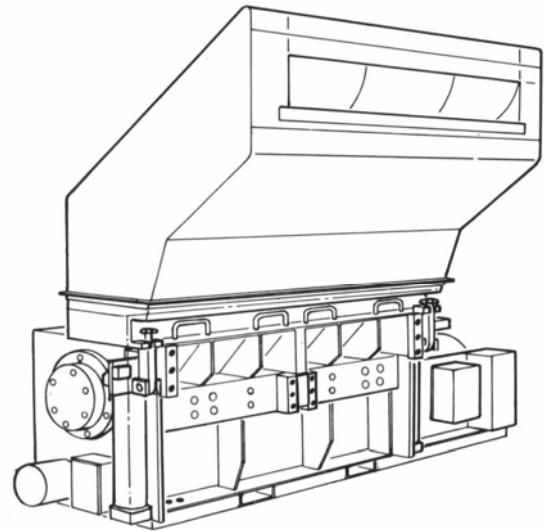

**Specifications**

Model	MT1456	MT1462
Cutting Circle	14" (360mm)	
Throughput	2200 lbs/hr (1000 kg)	3000 lbs/hr (5227 kg)
Cutting Chamber	2-Knife Bed, Twinshear™	
Rotor Knives	HCHC, 55, Chevron	
Discharge	8" (14 x 56) and 10" (14 x 62) airveyor chute	
Motor	50 HP, 1200 RPM, TEFC, 3/60/230/460	
Drive Parts	V-belt	
Base	Low profile airveyor	
Electrical Components	NEMA 12 with safety interlocks	
Controls	Customer supplied	
Feed Height	14" x 56" (356 x 1422 mm)	14" x 62" (356 x 1568 mm)
Overall Height		
Overall Length		
Overall Width (A)		
Weight	11,500 lbs (5227 kg)	17,000 lbs (7727 kg)

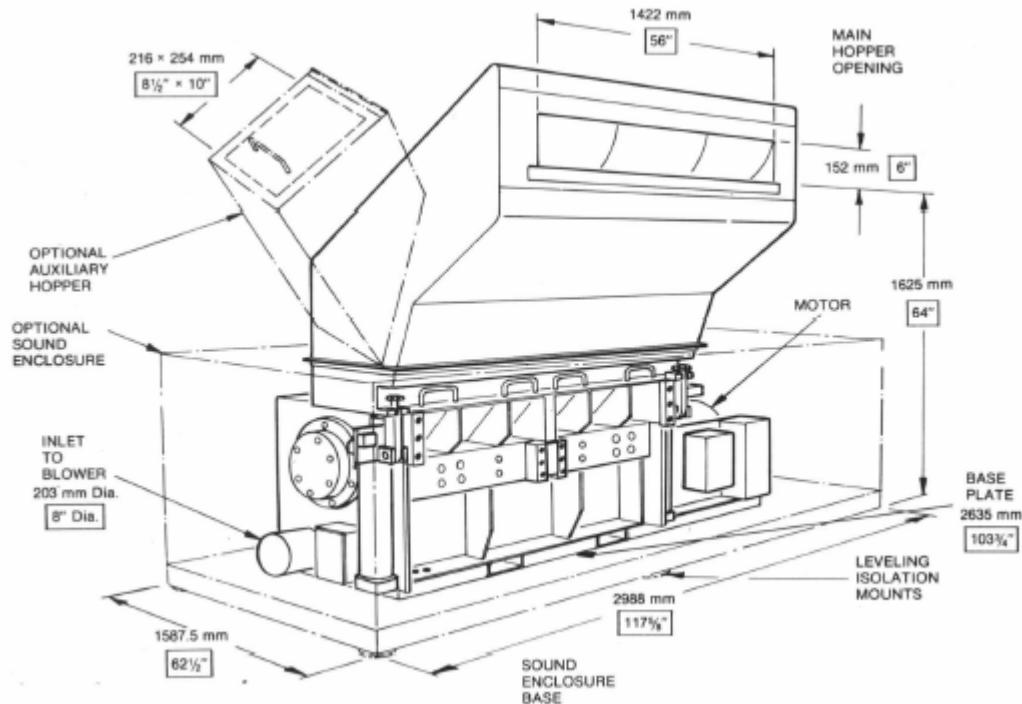
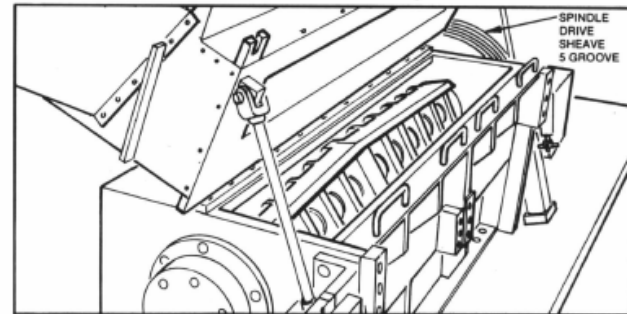

[www.colortronicna.com](http://www.colortronicna.com)

**Corporate Headquarters:**  
Colortronic North America, Inc.  
4100 Market Place  
Flint, MI 48507  
PH: 810-720-7300  
FX: 810-720-2598  
[colortronicweb@corpemail.com](mailto:colortronicweb@corpemail.com)

Dimensions and data not binding. Copyright by Colortronic 2004.