

MT1200 Series Thermforming Granulators

The MT1200 Series granulators offer a wide range of capabilities and are ideal for under-the-press or in front of the press applications. Three models provide various throat sizes – 12x44, 12x56 and 12x74. Models feature a horsepower range of 20 to 50 HP and throughput capacities of 1800 to 3000 lbs/hour. Reversible screens are available in various sizes and the complete regrind evacuation is achieved with an 8" blower system. The castered base is portable and low-profile, which allows for under-the-press positioning.

Standard Features

- 3-knife open Twin Shear rotor, 5-blade open rotors are available
- Bolted and dowelled construction
- Pivoting screen cradle
- 2 bed knives – reversible D2
- Rotor knives hi-angle
- Feed roll motor (3 HP AC)
- Oversized 7" dia. steel knurled feed rolls, optional paddle rolls are available
- 12" Cutting Circle
- Low profile caster base
- NEMA 12 controls
- 8" pneumatic discharge
- 1 year warranty on parts and labor

Optional Features

- No options available



Pneumatic upper hopper opening allows for easy access. Rotor and bed knives are easily accessed by tilting open the upper chamber.

CR4-570.1



The 3-blade open Twin Shear cutting geometry offers quieter, cooler operation and is ideal for polypropylene.



The two pivoting doors allow complete access into the bottom of the cutting chamber (screen cradle and screen). The 12" cutting circle and open screen area allow maximum throughput.



Two swing open doors allow easy access to the screen cradles and screen.

5/09

| Specifications | | | |
|--------------------------|--|---------------|---------------|
| Model | MT1244 | MT1256 | MT1274 |
| Throat Size | 12x44 | 12x56 | 12x74 |
| Cutting Circle, dia. in. | 12 | | |
| Feed Height, in. (mm) | 29.88 (729) | | |
| Throughput (lbs./hr) | 1800 | 2200 | 3000 |
| Working Envelope (LXW) | 91x73 | 103x73 | 121x73 |
| Weight, lbs. | 4000 | 5300 | 8000 |
| Motor (rotor drive) | 20-50 HP | | |
| Motor (feedroll drive) | 3 HP AC | | |
| Controls | 230/460V: 115V P/B (standard), 208/575V 155V P/B (optional) | | |
| Rotor | 3-knife open Twin Shear (standard), 5-knife open Twin Shear (optional) | | |

| Dimensions | | | | | |
|-------------------|---------------|---------------|---------------|---------------|---------------|
| Model | A, in. | B, in. | C, in. | D, in. | E, in. |
| CT1244 | 47 | 44 | 91 | 8 dia. | 5.4 |
| CT1256 | 59 | 56 | 103 | 8 dia. | 5.4 |
| CT1274 | 77 | 74 | 121 | 10 dia. | 6.4 |

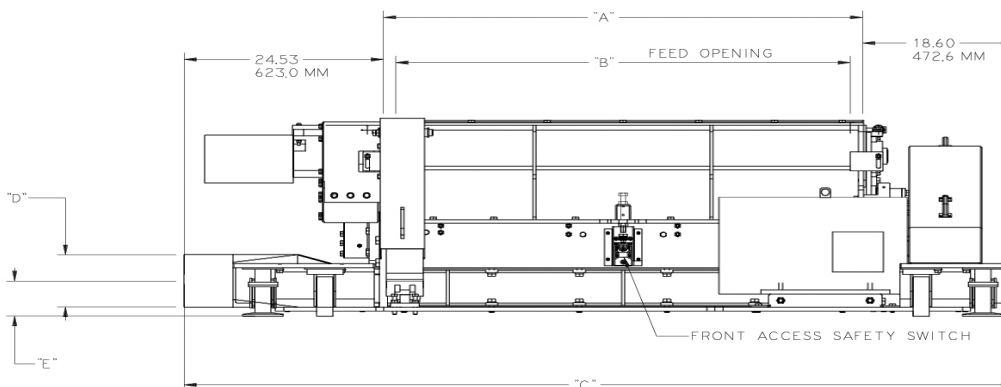
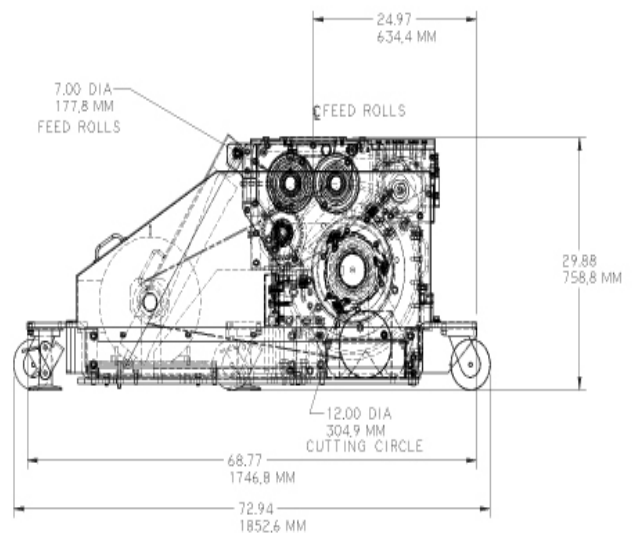

www.colortronicna.com

Corporate Headquarters:
Colortronic North America, Inc.
4100 Market Place
Flint, MI 48507
PH: 810-720-7300
FX: 810-720-2598
colortronicweb@corpemail.com

Dimensions and data not binding. Copyright by Colortronic 2009