

Typical Scrap Reclaim System

- A – Film Grinder
- B – Edge Trim Conveying System
- C – Fluff Feed Hopper
- D – Cyclone

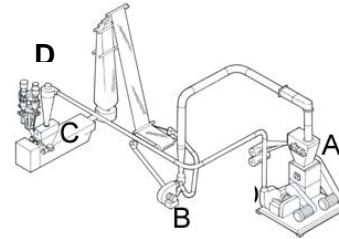

Brief Description

Colortronic agitated fluff storage tanks are designed with heavy-duty agitators to handle the hardest to feed materials. Sizes range from 50 to 200 cu. ft. capacity.

- Rectangular heavy-duty round bottom design
- Cleanout access door
- Slow speed gear reduction drive agitator
- Tank-mounted controller
- Fluff conveying blower
- Lexan cover over auger discharge chute
- Mechanical high level switch with warning light
- 230/1/60 agitator operating voltage
- 460/3/60 blower operating voltage



FT Series Fluff Storage Tank Specifications

American Standards

Model Number	Capacity cu. ft.	Discharge auger in. dia. OD	Auger drive HP DC	Agitator drive HP DC	Discharge blower HP	Blower tube in. dia. OD	Tank dimensions, in.		
							L	W	H
50-4-STD	50	4	1/2	3/4	2	4	54	36	69
100-6-STD	100	6	3/4	1	5	4	54	36	87
200-6-STD	200	6	1	2	5	4	54	36	150

Metric Standards

Model number	Capacity liters	Discharge auger mm dia. OD ①	Auger drive kW DC	Agitator drive kW DC	Discharge blower kW	Blower tube mm dia. OD ①	Tank dimensions, cm		
							L	W	H
50-4-STD	1,415	101.6	0.373	0.559	1.492	101.6	137	91	175
100-6-STD	2,832	152.4	0.559	0.746	3.730	101.6	137	91	221
200-6-STD	5,663	152.4	0.746	1.492	3.730	101.6	137	91	381

① Diameters in millimeters are approximate.

FT series Agitated Fluff Tanks

Tank model	Capacity
50-4-STD	50 cu. ft. (1,415 liter)
100-6-STD	100 cu. ft. (2,830 liter)
200-6-STD	200 cu. ft. (5,660 liter)

FT Series Available Options

✓ denotes availability

Option description	Availability
Special voltage; Specify	✓
Photo cell level switch with delay timer in lieu of mechanical	✓
Special cyclone hole in cover	✓
Diverter valve and controls to feed two (2) extruders	✓

- See reverse side for agitated fluff storage tank configurations -

Typical FT Series Agitated Fluff Storage Tank Configuration

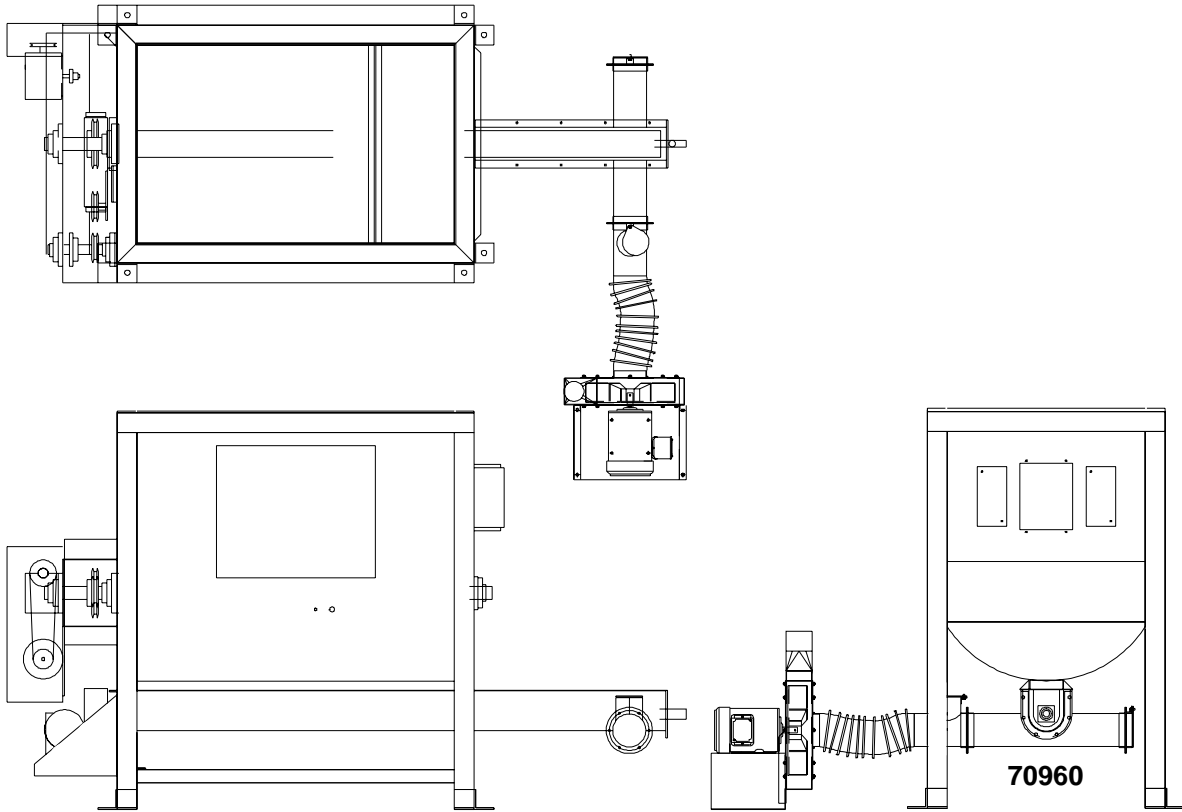

Typical FT Series Agitated Fluff Storage Tank with Reclaim System Configuration

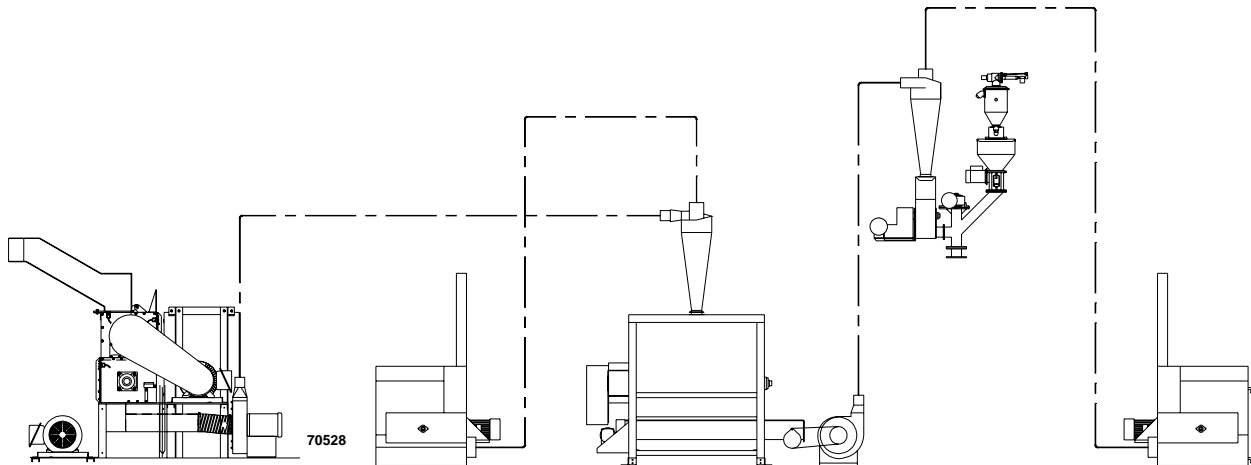

www.colortronicna.com

Corporate Headquarters:
Colortronic North America, Inc.
4100 Market Place
Flint, MI 48507
Tel. 810-720-7300
Fax. 810-720-2598
colortronicweb@corpemail.com

Dimensions and data not binding. Copyright by Colortronic 2005.