

MXS Series Single Shaft Shredder

Designed for processing plastic waste for reclamation and recycling, large extruder purgings, large reject parts, trim scraps, baled or loose film, synthetic fiber, wood processing scrap, medical waste, cardboard, paper, and carpet, all of the MXS Series Shredders feature the following:

Standard Features

- Sturdy “swing-style” ram minimizes space and allows product to fall into the rotor
- Serrated ram plate for holding product into the rotor
- Outboard mounted bearings reduce contamination
- Reversible square cutters for quick changes
- Large 29.5” (750mm) diameter rotor for positive ingestion
- Bolted-in cutter seat for easy removal and maintenance
- Abrasion resistant rotor standard for long life
- Dual motor driven for even hp displacement on both shaft ends
- Two speed ram hydraulics

Optional Features

- Hydraulic screen cradle
- Rotor cooling
- PLC with display
- Chamber wear protection
- Infeed and discharge conveyors
- Easily configured with 2nd stage granulation



The “U” rotor is the industry’s most successful cutting rotor design. “U” model is for wood grinding, light plastics, and light waste. “K” model is for demanding plastics, wood, paper, and waste.



Large diameter rotor with “swing style” ram and serrated front surface.



Two stage hydraulics with air cooler for long life.



Specifications

Standard Description	MXS 1500	MXS 2000	MXS 3000
Large capacity hopper feed opening, in (mm)	102.4 x 63.8 (2600 x 1620)	102.4 x 79.5 (2600 x 2020)	100 x 108.7 (2540 x 2760)
Usable open area of cutting chamber, in (mm)	59.1 x 58.7 (1500 x 1490)	59.1 x 74.8 (1500 x 1900)	59.1 x 106.3 (1500 x 2700)
Standard rotor in hp (kW)	2x100 hp (2x75)	2x100 hp (2x75)	2x150 hp (2x110)
Number of cutters	76	96	136
Number of bed blades	4	5	7
Rotor diameter, in (mm)	29.5 (750)	29.5 (750)	29.5 (750)
Rotor speed, rpm	54		
Motor of hydraulic device, hp (kW)	15 (11)		
Screen sizes available, in (mm)	1-4 (20-100)		
Mounted knife holders	Included		
Hopper for manual/conveyor feeding	Included		
Hydraulic feeding ram	Included		
Two speed turbo-hydraulic	Included		
Ram comb plate	Included		
Control panel SPS	Included		
Ampere-meter in control cabinet	Included		

Dimensions	MXS 1500	MXS 2000	MXS 3000
Length A, in (mm)	141.7 (3600)		
Length B, in (mm)	102.4 (2600)		
Length C, in (mm)	34.3 (870)		
Length D, in (mm)	131.9 (3350)		
Length E, in (mm)	99.9 (2540)		
Width F, in (mm)	125.9 (3200)	154.7 (3930)	192.9 (4900)
Width G, in (mm)	63.7 (1620)	79.5 (2020)	111 (2820)

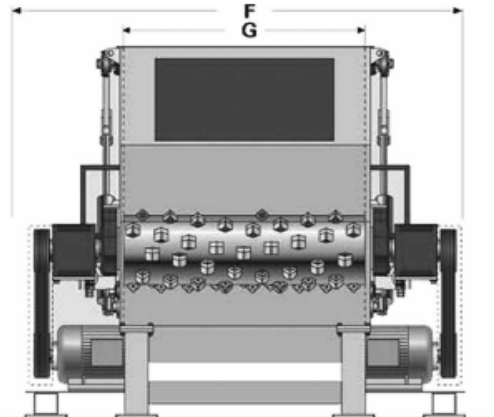
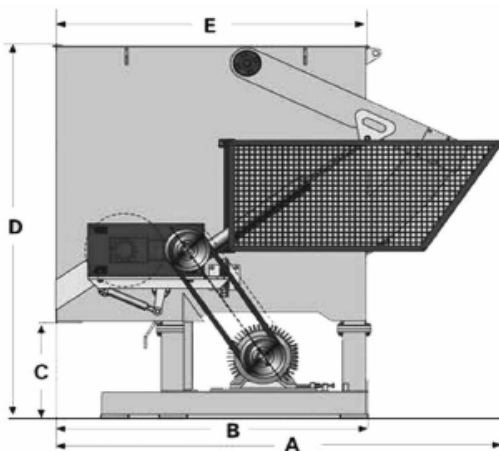

Colortronic North America, Inc.
4100 Market Place
Flint, MI 48507
PH: 810-720-7300
FX: 810-720-2598
www.colortronicna.com

Dimensions and data not binding. Copyright by Colortronic 2008.