

Typical set-up for a single conveying unit.

- A Single Conveying Unit
- B Dosing System
- C Processing Machine
- D Suction Pipe

Component A is described below.

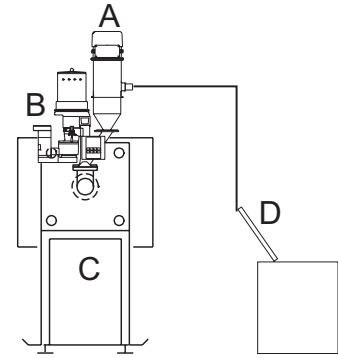

Brief Description

Application

Colortronic single conveying units are designed for use in facilities in which require independent machine conveying systems.

The CSE single conveying units have been developed for conveying thermoplastic granules. A typical area of application is for processing machines and drying hoppers with throughputs of up to 360 kg/hr (790 lbs/hr).

- Colortronic single conveying units are designed for continuous 24-hour operation.
- Colortronic single conveying units meet the European "CE" requirements.

Rugged, modular construction

The CSE excels due to it's compact design making it possible to mount the unit onto smaller machines and drying hoppers.

A highly efficient vacuum pump guarantees that large throughputs of material can be conveyed regardless of space constraints.



Technical Information

Basic Version

- Integrated control, mounted at the rotating turbine head
- Integrated vacuum turbine
- Cleaning and maintenance flap
- Parts coming in contact with material are made of stainless steel
- Easy to remove turbine head for quick cleaning

Optional Equipment

- Integrated textile filter with pneumatic cleaning
- High Comfort Control
 - Granulator level sensor input
 - Two-component valve output
 - Material clearing valve output
 - Automatic shut down with lack of material, incl. alarm output

Performance

- Maximum throughput: 360 kg/h (790 lbs/hr)
- Hopper loader capacity: appr. 5 l
- Connected load: 230 V, AC, N, PE, 50 Hz, 1.2 kW
- Noise level appr. 80 dB/A

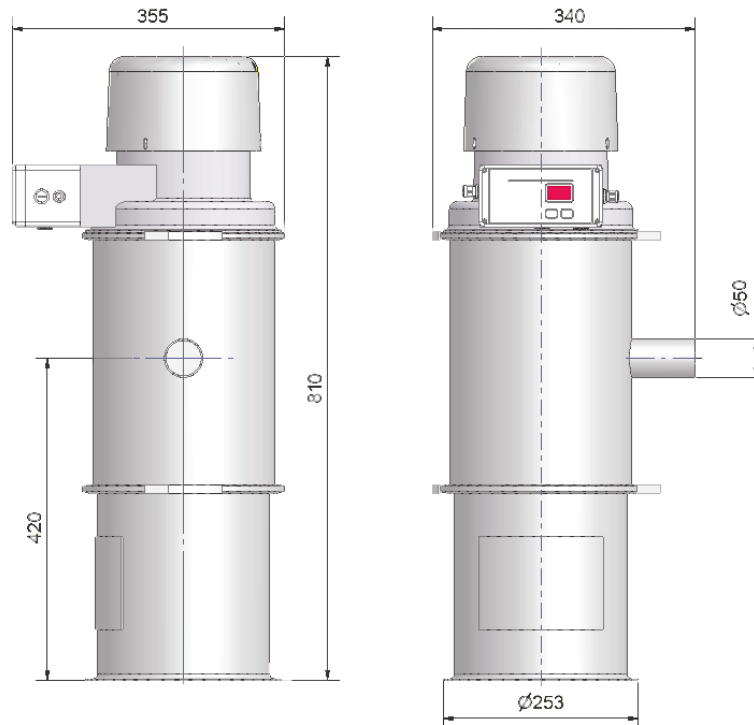

www.colortronicna.com

Colortronic GmbH
Germany

☎ +49 61 75 7 92-0
☎ +49 61 75 7 92-1 79
✉ info@colortronic.de

Colortronic AG
Switzerland

☎ +41 62 889 25 25
☎ +41 62 889 25 26
✉ info@colortronic.ch

Colortronic Inc.
USA

☎ +1 810 720 7300
☎ +1 810 720 2598
✉ colortronicweb@corpemail.com

Colortronic Systems Pte. Ltd
Singapore

☎ +65 677 77 665
☎ +65 677 88 671
✉ ctasia@colortronic.com

Colortronic s.a.r.l.
France

☎ +33 03 88 59 18 10
☎ +33 03 88 59 18 11
✉ ctfrance@colortronic.com

Colortronic srl
Italy

☎ +39 0 131 87 29 33
☎ +39 0 131 87 29 41
✉ info@colortronic.it

Colortronic U.K. Ltd.
Great Britain

☎ +44 12 46 260 222
☎ +44 12 46 455 420
✉ sales@colortronic.co.uk