

Typical application of a gravimetric batch blender.

- A Gravimetric Batch Blender
- B Control Unit
- C Printer
- D Host

Component A is described below.

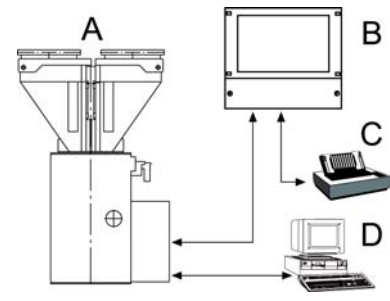

Brief Description

Colortronic's gravimetric batch blender Ultrablend 675 is ideally suited for blending granulates, regrinds and non-compacting powders (less than 5%)

High dosing accuracy and consistency improves end product quality and saves money by using less additives and reducing scrap. The Ultrablend 675 is specially designed for direct mounting on injection molding machines and extruders with a throughput up to 1,543 lbs/hr (700 kg/hr). All products are dosed and weighed one after another into a weigh bin supported by a single load cell. Once all components are weighed, they are passed to the mixing chamber where they are homogenized before exiting the blender.

- Ultrablend is easy to maintain and designed for continuous, 24 hour operation.
- Ultrablend meets the European "CE" requirements

Rugged, modular construction

Gravimetric batch blender for up to six components. Stainless steel material contact surfaces. The product is weighed with a single load cell, eliminating need for load cell matching. The vertical slide gate design improves accuracy and results in a compact design. The modular construction for extension hoppers and conveying system integration guarantees high flexibility.



Technical Data

Basic Version

- Up to 6 dosing components
Max. 4 slide gates / max. 4 screw feeders
- Weigh hopper volume: 0.18 cu. ft. (8 liters)
- Mixer volume: 0.88 cu. ft. (25 liters)
- Dosing hopper volume: .09/.21/.335/.88 cu. ft.
(2.6/6/10/25 liters)
- Maximum throughput (2 components, free flowing granulate, density 0.6 kgs/l): 1,540 lb/h (700 kg/h)
- Operating voltage: 400V +/- 10%, 3AC, 50-60Hz
- Air pressure: 6 bar
- Weight (4 components): 90 kgs
- Control unit UB Touch

Versions

- Dosing hopper SV-M for granules and regrind
0.88 cu. ft. (25 l), max. 270 g/s
- Dosing hopper SV-S for granules and regrind
0.21 cu. ft. (6 l), max. 120 g/s
- Screw feeder DS05 for granules and regrind
0.08 cu. ft. (2.2 l), max. 8 g/s
- Screw feeder CT22 for granules and regrind
- Screw Feeder CS65 for granules and regrind

Optional Equipment

- Screw feeders DS05; CT22; CS65
- Manual or pneumatic slide gate below the blender
- Level sensor control of slide gate below the blender
- Hopper extension modules
- Conveying systems
- Level sensors in dosing hoppers
- Machine adapters
- Special voltages
- Host communication via Modbus
- Central blender stand with single and triple suction box

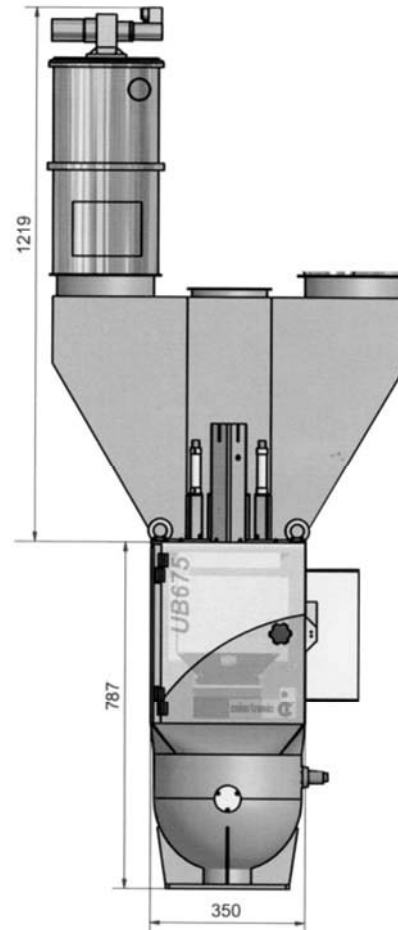

www.colortronicna.com

Corporate Headquarters:

Colortronic North America, Inc.
4100 Market Place
Flint, MI 48507
Tel. 810-720-7300
Fax. 810-720-2598
colortronicweb@corpemail.com

Dimensions and data not binding. Copyright by Colortronic 2005.