

Variable Frequency Systems

Colortronic's Variable Speed Systems control either water pressure by varying the speed of the pump, or cooling tower water temperature by varying the speed of a tower fan.

The basic system consists of three components: pressure or temperature transmitter, speed controller, and single variable frequency drive; wall-mount, NEMA 1.

Standard Features

An operator enters the pressure or temperature he wants to maintain into the controller. While in operation, the controller monitors the actual pressure or temperature by using a 4-20ma signal from the transmitter. After comparing the actual condition with the set point, the controller sends a PID-controlled speed signal to the variable frequency drive, telling it to speed up or slow down. The controller does not start and stop the drive, but only tells it how fast to go.

Colortronic's variable frequency drive features Hand, Off, and Automatic keys, allowing an operator to set the speed manually or allow the controller to adjust the speed automatically. Drives are UL/CUL listed and can display motor current, running hours, hp, kW, and other parameters for a total of 25 selections. Each drive comes with manufacturer's startup and an 18-month warranty.

Optional Features

- Disconnect and fuses
- 4-20ma pressure transmitter
- 4-20ma temperature transmitter and well
- 0-10 VDC variable speed pressure controller
- 0-10 VDC variable speed temperature controller
- Electrical enclosure to house speed controller and other accessories (not needed if NEMA panel is purchased with pump tank)



Specifications

HP, 460/3/60 voltage ①	Height, in.	Width, in.	Depth, in.	Weight, lbs.
≤ 3	15.55	8.66	6.30	18
5	15.55	8.66	7.87	23
7.5	15.55	8.66	7.87	23
10	15.55	8.66	7.87	23
15	22.05	9.53	10.24	51
20	22.05	9.53	10.24	51
25	22.05	9.53	10.24	51
30	27.56	9.53	10.24	66
40	27.56	9.53	10.24	66
50	31.50	12.13	11.65	106
60	31.50	12.13	11.65	106
75	37.56	14.57	13.19	267

① Consult factory for other voltages

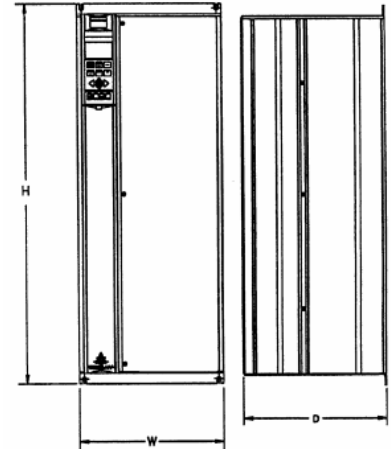

Application Uses

1. Improved process control and machine operation by maintaining tight cooling water supply pressure and tower water temperature.
2. Reduced operating costs by running motors only at the horsepower required. Match electrical input to cooling system demand.
3. Built in soft start minimizes inrush current to the motor and the mechanical shock of across-the-line hard starts.
4. Eliminates the constant starting and stopping of tower fan motors while providing better temperature control. Instead of the constant hammering of starting and stopping the variable frequency drive puts the motor to sleep until the demand rises.
5. Eliminate water hammer by slowly increasing and decreasing pump speed as demands fluctuate.
6. Controlled shutdown on loss of plant power. Motors will slow to a stop until the drive DC bus has discharged. Upon the return of plant power a controlled acceleration brings the motors back up to speed.
7. Monitor motor performance. Data such as motor current, power (kW or hp), energy (kWh), running hours, and more can be read from the variable frequency drive or sent to a data collection center.
8. Utilize the amount of output required to reduce energy usage and extended life of pumps. Benefit from energy conservation programs which may be offered by local utilities.

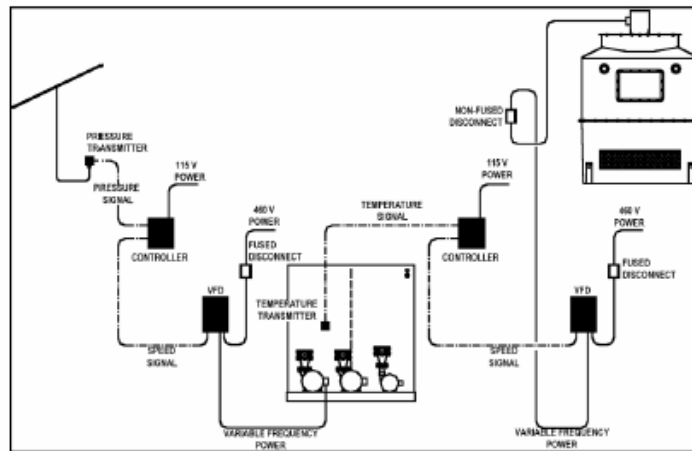

www.colortronicna.com

Corporate Headquarters:
 Colortronic North America, Inc.
 4100 Market Place
 Flint, MI 48507
 PH: 810-720-7300
 FX: 810-720-2598
colortronicweb@corpemail.com

Dimensions and data not binding. Copyright by Colortronic 2004.