

Typical application of a gravimetric batch blender.

- A Gravimetric Batch Blender
- B Control Unit
- C Printer
- D Host

Component A is described below.

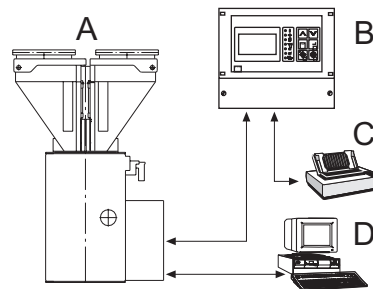

Description

Colortronic's gravimetric batch blender Ultrablend 375 is ideally suited for blending granulates, regrinds and non-compacting powders (less than 5%).

High dosing accuracy and consistency improves end product quality and saves money by using less additives and reducing scrap. The Ultrablend 375 is specially designed for direct mounting on injection molding machines and extruders with a throughput up to 375 kg/hr. All products are dosed and weighed one after each other into a weigh bin supported by a single load cell. Once all components are weighed, they are passed to the mixing chamber where they are homogenized before exiting the blender.

- Ultrablend is easy to maintain and designed for a 7 day, 24 hour operation.
- Ultrablend meets the european "CE" requirements.

Rugged, modular construction

Gravimetric batch blender for up to four components. Stainless steel material contact surfaces. The Product is weighed with a single load cell, eliminating need for load cell matching. The vertical slide gate design improves accuracy and results in a compact design. The modular construction for extension hoppers and conveying system integration guarantees high flexibility.

Technical Data

Basic Version

- Up to 6 dosing components
max. 4 slide gates / max. 4 screw feeders
- Weigh hopper volume: 4 Liters
- Mixer volume: 10 Liters
- Dosing hopper volume: 2.2/6/10/25 Liters
- Maximum throughput (2 components): 400 kg/hr
- Operating voltage: 400 V +/- 10 %, 3AC,50-60Hz
- Air pressure: 6 bar
- Weight (4 components): 70 kgs
- Control unit C180

Optional Equipment

- Screw feeders DS05; CT22; CS65
- Manual or pneumatic slide gate under blender
- Level sensor control of slide gate below the blender
- Hopper extension modules
- Conveying systems
- Level sensors in dosing hoppers
- Machine adapters
- Special voltages
- Host communication via Modbus
- Central blender stand with single and triple suction box

Versions

- Dosing hopper SV-M for granules and regrind
25 l, max. 270 g/s
- Dosing hopper SV-S for granules and regrind
6 l, max. 120 g/s
- Screw feeder DS05 for granules and regrind
2.2 l, max. 8 g/s
- Screw feeder CT22 for granules and regrind
- Screw feeder CT65 for granules and regrind

Dimensions

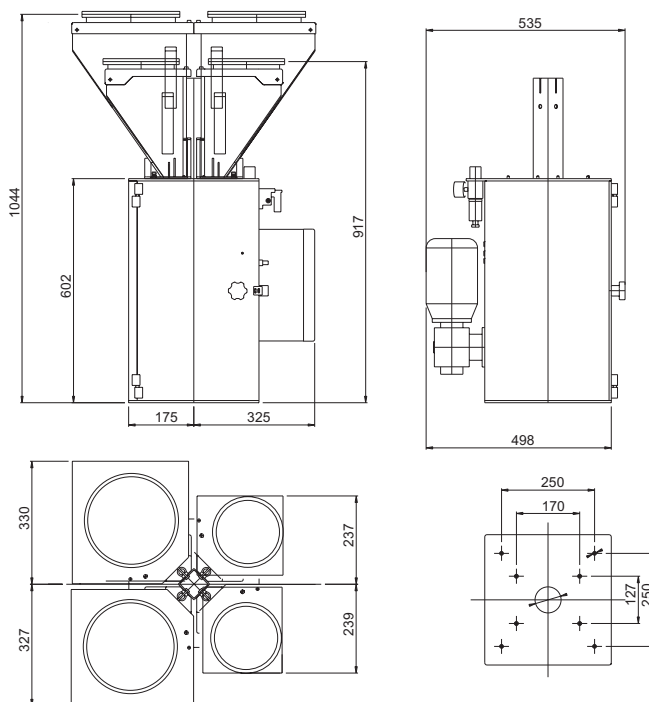

www.colortronicna.com

Colortronic GmbH
Germany

☎ +49 61 75 7 92-0
☎ +49 61 75 7 92-1 79
✉ info@colortronic.de

Colortronic AG
Switzerland

☎ +41 62 889 25 25
☎ +41 62 889 25 26
✉ info@colortronic.ch

Colortronic Inc.
USA

☎ +1 810 720 7300
☎ +1 810 720 2598
✉ colortronicweb@corpemail.com

Colortronic Systems Pte. Ltd
Singapore

☎ +65 677 77 665
☎ +65 677 88 671
✉ ctasia@colortronic.com

Colortronic s.a.r.l.
France

☎ +33 03 88 59 18 10
☎ +33 03 88 59 18 11
✉ ctfrance@colortronic.com

Colortronic srl
Italy

☎ +39 0 131 87 29 33
☎ +39 0 131 87 29 41
✉ info@colortronic.it

Colortronic U.K. Ltd.
Great Britain

☎ +44 12 46 260 222
☎ +44 12 46 455 420
✉ sales@colortronic.co.uk