

Typical application of a volumetric dosing system.

- A Conveyor unit
- B Dosing station
- C Collecting tank
- D Rotary vane

Components B and C are described below.

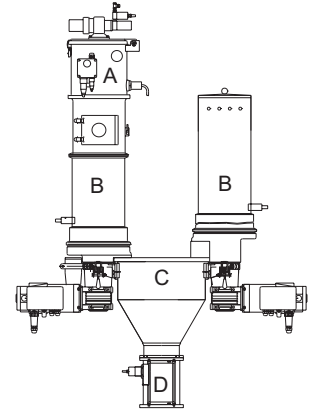

Brief Description

The Synchroblend dosing system employs the volumetric dosing principle. In this system each component is proportioned in precisely uniform units and added synchronously with the other components. Due to this synchronous dosing all components will always arrive at the same point of time and according to the mixing proportions specified by the recipe in the collecting tank. This ensures that the mixture complies with the recipe at any point of the dosing procedure; furthermore, no mechanical mixer is required for granule processing. Due to the reduced amount of stock above the feed area, separation is prevented reliably even when processing critical additives.

In order to ensure a uniform mixture, an additional blending unit can be used when processing powdered additives with regrinds.

All dosing stations are designed as exchangeable stations, i.e. they can be easily replaced, for example if materials and colours are changed frequently.

The microprocessor control system can store up to 50 recipes. All messages are displayed in plain text and stored in an event journal. Essential functions are protected by password against unauthorized access. The control system is equipped for communication. A printer can also be connected to the system.



Technical Information

Basic Version

- Max. 8 dosing stations
- Granule processing
- Powder processing
- Microbatch processing
- Level sensor in collecting tank
- Recipe memory
- Plain text display
- Event journal
- Password protection for essential functions
- Equipped for systems communication

Optional Equipment

- Level sensor in the hopper
- Rotary vane with 3 working positions under collecting tank
- Flat slide valve under collecting tank
- Printer connection
- Interfaces

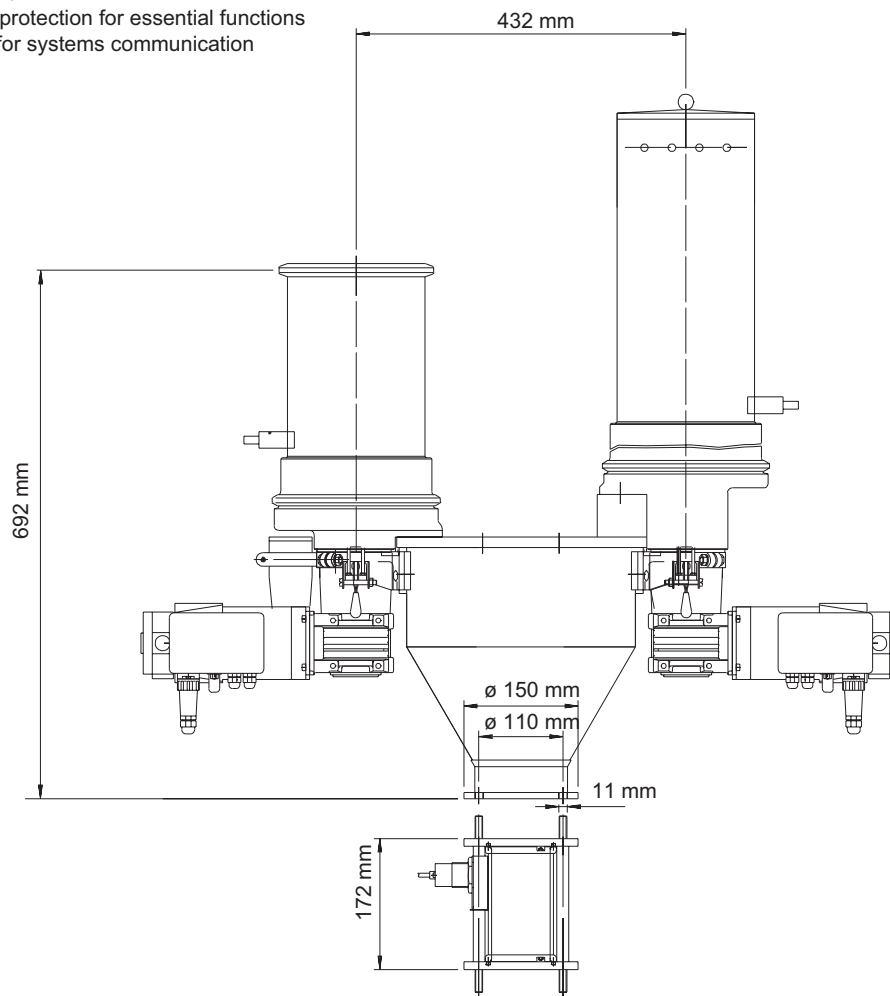

www.colortronicna.com

Colortronic GmbH
Germany

☎ +49 61 75 7 92-0
 📠 +49 61 75 7 92-1 79
 ✉ info@colortronic.de

Colortronic Inc.
USA

☎ +1 810 720 7300
 📠 +1 810 720 2598
 ✉ colortronicweb@corpemail.com

Colortronic Systems Pte. Ltd
Singapore

☎ +65 77 77 665
 📠 +65 77 88 671
 ✉ ctasia@colortronic.com

Colortronic U.K. Ltd.
Great Britain

☎ +44 12 46 260 222
 📠 +44 12 46 455 420
 ✉ sales@colortronic.co.uk

Colortronic s.a.r.l.
France

☎ +33 03 88 59 18 10
 📠 +33 03 88 59 18 11
 ✉ ctfrance@colortronic.com

Colortronic AG
Switzerland

☎ +41 62 889 25 25
 📠 +41 62 889 25 26
 ✉ info@colortronic.ch